

Solutions for Squeak & Rattle Prevention:

## The Altair Squeak and Rattle Director

Identify & Eliminate Squeak & Rattle Phenomena

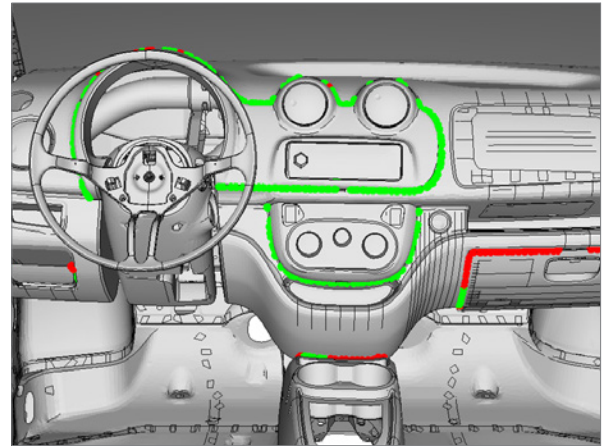
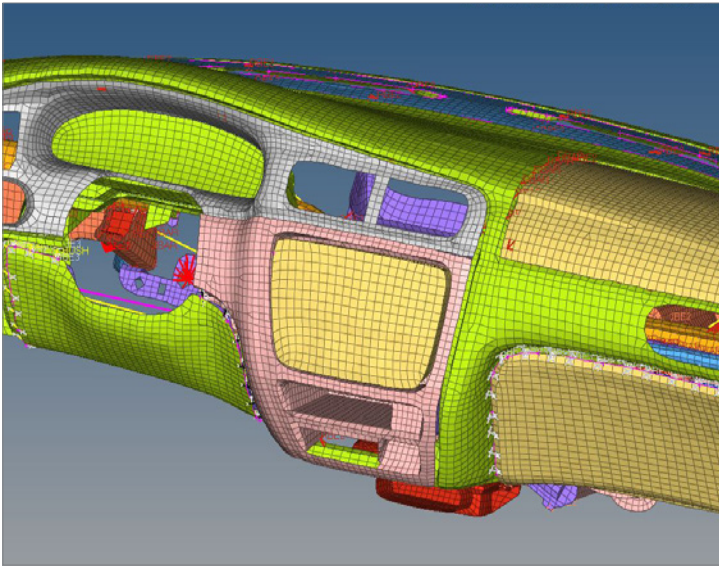

### Highlights

- Identifies risk zones for squeak and rattle from the earliest development phase
- Automates repetitive pre and post-processing calculations
- Presents results in a standardized format
- Decreases the time to perform squeak and rattle analysis by up to 80%

#### Ideal for:

Organizations that design products where unwanted noise can negatively affect customer satisfaction

# A Simulation Based Prevention Method

Reducing the presence of interior Squeak and Rattle (S&R) noises is an on-going concern in the automotive and aerospace sectors. Manufacturers require suppliers to build vehicle modules free of S&R issues as silence has become synonymous with luxury and quality to customers. Companies often rely on system level or full-vehicle prototype testing methods but this is time consuming and takes place far too late in the development process, leading to high costs and unnecessary material usage.

Altair's Squeak and Rattle Director (SnRD) is a novel set of software automations to rapidly identify and analyze design alternatives to eliminate the root causes of squeak and rattle (S&R) in assemblies. Tailored to be deeply integrated within your environment and processes, SnRD offers a complete set of capabilities to streamline the entire S&R simulation workflow process from model creation to results visualization. Fully integrated in HyperMesh and HyperView, this user-friendly solution provides a highly semi-automated approach to determine relative component displacements in the time domain that can lead to undesired squeaking and rattling in products.

## 1. Set up the Finite Element Model

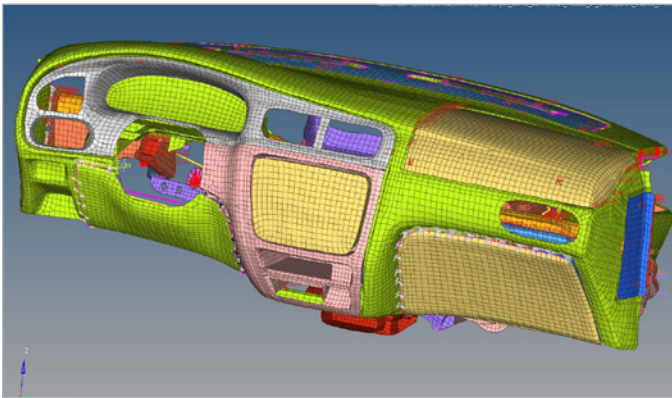

- Import Interface locations from **CAD, GD&T information and stick slip data**
- E-Line interface creation - **manual or automatic**
- **E-Line management system** to visualize, review and modify different attributes

## 2. Define a Virtual Testing Rig

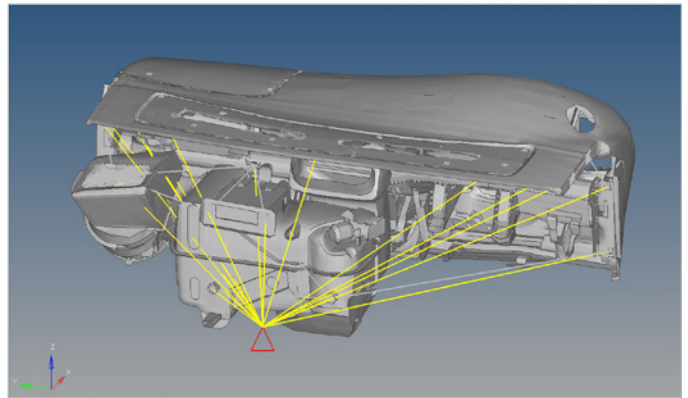

- Guided process for **modal transient load case setup**
- **Import load** from the test or other simulation results (multi-body simulation)
- **Automatic** definition of outputs and export an **input deck ready to run**

## 3. Analyse the Squeak & Rattle

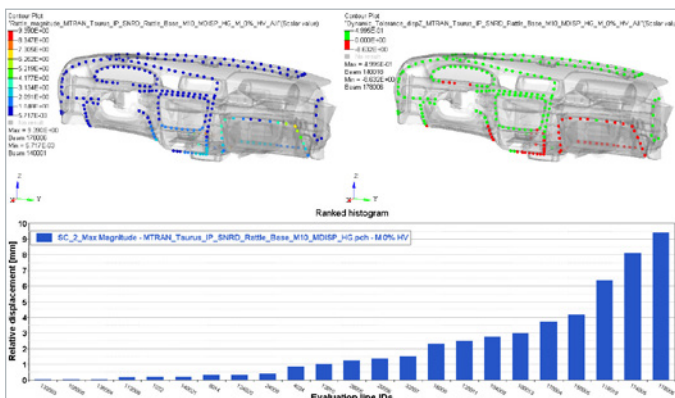

- **Automatic post-processing** to identify Rattle & Squeak risk areas
- **Rattle assessment** using Relative displacement vs Gap dimension and tolerances
- Squeak assessment using max principal peak to peak vs stick slip test data

## 4. Interpret the results to find solutions

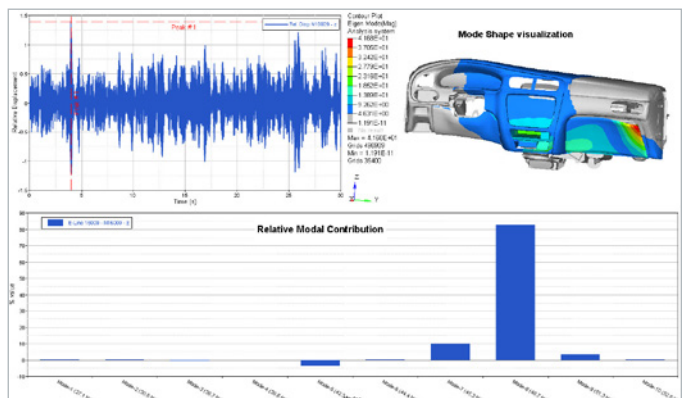

- Time domain plot of relative displacement **enabling correlation with physical test**
- **Root cause analysis** with Relative Modal Contribution calculation for dominant frequencies
- **Sensitivity analysis** to study what if scenarios and find the potential for improvement (Optimization)

## Upfront Simulation to Reduce Lead Time

By identifying potential areas of concern in the early stages of design, the overall design quality can be improved and significant cost and time savings can be realized.

### Traditional Test Based Design Approach

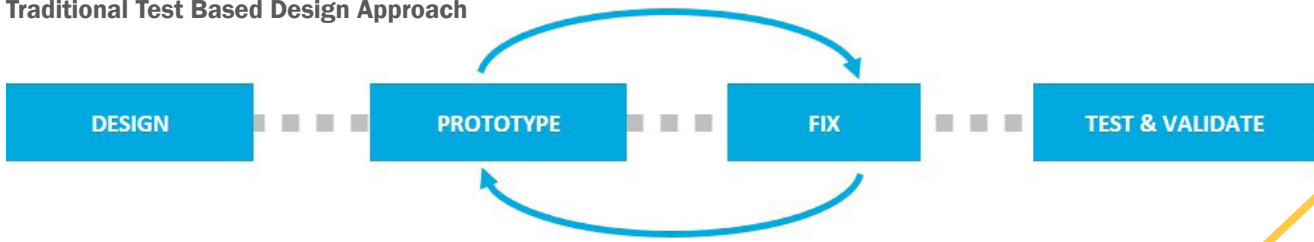

### Altair's Simulation Base Approach

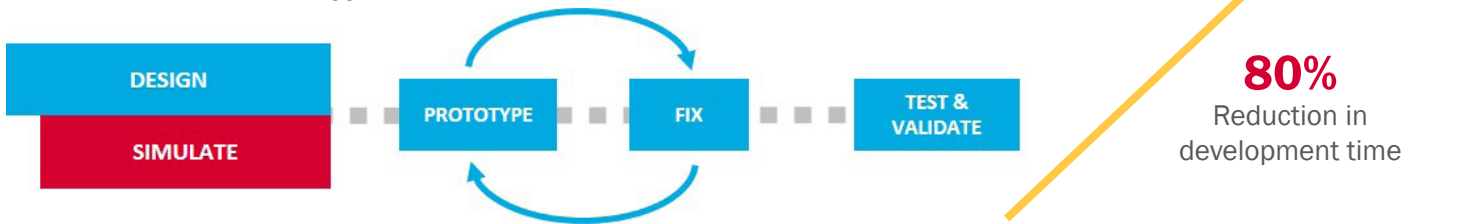

## A Complete Squeak & Rattle Prevention Process

Altair's leadership in simulation based squeak & rattle risk identification and design optimization relies on the expertise of its product design team. Altair ProductDesign has gathered this expertise to create the Squeak & Rattle Director, the most comprehensive solution on the market. The solution enables clients to seamlessly implement this unique simulation methodology directly into existing design processes.

The complete solution results from combining Altair & Ziegler Instruments (ZINS) expertise: CAE, CAD assembly Contact Point Analysis as well as testing of material pairs through the ZINS PEM DataBase and complete system assemblies. This exclusive collaboration has created a unique and efficient solution for squeak and rattle prevention.

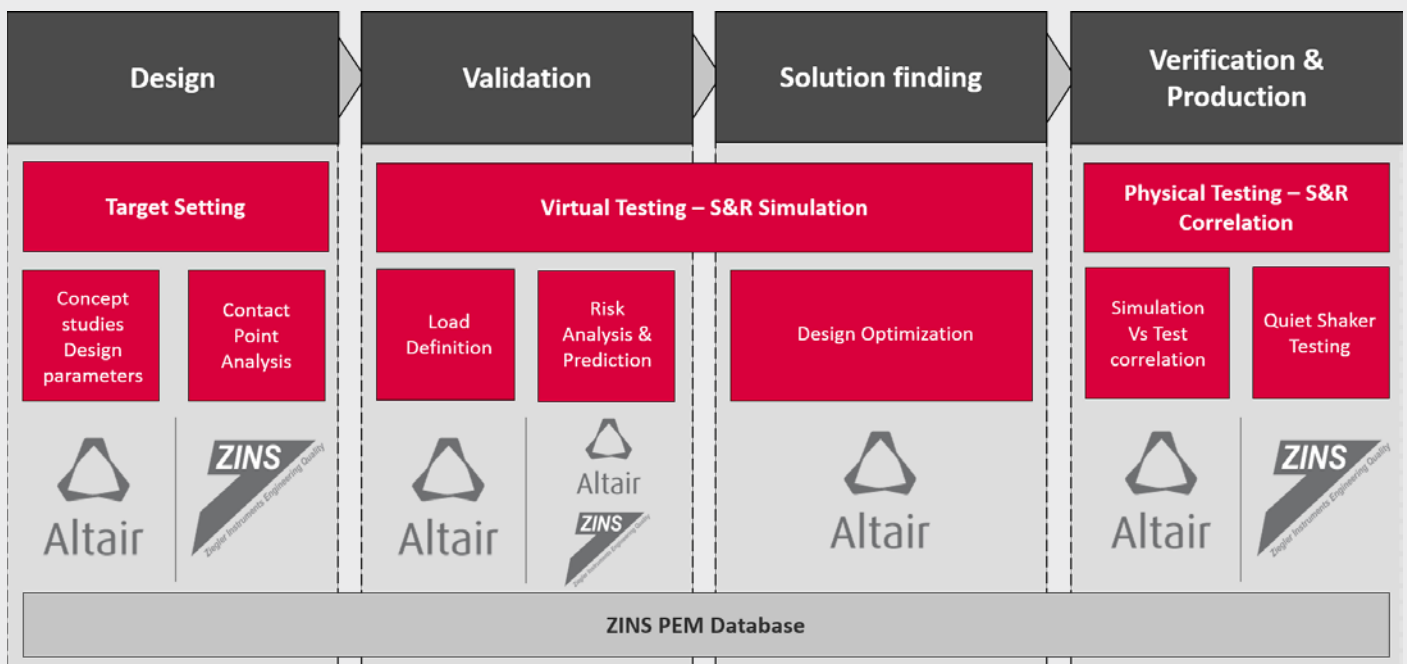

**A simulation based approach to S&R prevention underpinned by the ZINS PEM Database**

Learn more about Altair's  
**Squeak & Rattle Solutions**  
at [www.altair.com/squeak](http://www.altair.com/squeak)

## About Altair

Altair is focused on the development and broad application of simulation technology to synthesize and optimize designs, processes and decisions for improved business performance. Privately held with more than 2,600 employees, Altair is headquartered in Troy, Michigan, USA and operates more than 45 offices throughout 24 countries. Today, Altair serves more than 5,000 corporate clients across broad industry segments.

[www.altair.com](http://www.altair.com)

## About Altair ProductDesign

Altair ProductDesign is a global, multi-disciplinary product development consultancy of more than 800 designers, engineers, scientists, and creative thinkers. As a wholly owned subsidiary of Altair Engineering Inc., this organization is best known for its market leadership in combining its engineering expertise with computer aided engineering (CAE) technology to deliver innovation and automate processes. Altair ProductDesign utilizes proprietary simulation and optimization technologies (such as Altair HyperWorks) to help clients bring innovative, profitable products to market on a tighter, more efficient time-scale.

[www.altairproductdesign.com](http://www.altairproductdesign.com)

## About ZINS Ziegler Instruments

ZINS Ziegler Instruments GmbH offers Systems and Services for Squeak & Rattle, Annoying Noises, Touch Haptics and for Vibration and Noise Control is a trusted partner to the automotive industry. Ziegler improves the quality and perceived quality of the products for our customers, while provide outstanding features that create incentives to buy. With a worldwide network, Ziegler inspires trust, reliability, and partnership assisting with equipment, services and training.

[www.zins-ziegler-instruments.com](http://www.zins-ziegler-instruments.com)



**Altair Engineering, Inc., World Headquarters:** 1820 E. Big Beaver Rd., Troy, MI 48083-2031 USA  
Phone: +1.248.614.2400 • Fax: +1.248.614.2411 • [www.altair.com](http://www.altair.com) • [info@altair.com](mailto:info@altair.com)

Altair®, HyperWorks®, RADIOSS™, HyperMesh®, BatchMesher™, HyperView®, HyperCrash™, HyperGraph®, HyperGraph®3D, HyperView Player®, OptiStruct®, HyperStudy®, HyperStudy®DSS, MotionView®, MotionSolve™, Altair Data Manager™, HyperWorks Process Manager™, HyperForm®, HyperXtrude®, GridWorks™, PBS Professional®, and e-Compute™ are trademarks of Altair Engineering, Inc. All other trademarks or servicemarks are the property of their respective owners.